

# Model 1199 Diaphragm Seal Systems Manual



**ROSEMOUNT®**

FISHER-ROSEMOUNT™ Managing The Process Better.™



# Product Manual

## NOTICE

Read this manual before working with the product. For personal and system safety, and for optimum product performance, make sure you thoroughly understand the contents before installing, using, or maintaining this product.

Within the United States, Rosemount Inc. has two toll-free assistance numbers.

**Customer Central:** 1-800-999-9307 (7:00 a.m. to 7:00 p.m. CST)  
Technical support, quoting, and order-related questions.

**North American Response Center:** 1-800-654-7768 (24 hours a day – Includes Canada)  
Equipment service needs.

For equipment service or support needs outside the United States, contact your local Rosemount representative.

## CAUTION

The products described in this document are NOT designed for nuclear-qualified applications.

Using non-nuclear qualified products in applications that require nuclear-qualified hardware or products may cause inaccurate readings.

For information on Rosemount nuclear-qualified products, contact your local Rosemount Sales Representative.

### For Western Europe, please contact:

#### Fisher- Rosemount Diaphragm Seal Support

Heath Place  
Bognor Regis  
West Sussex PO229SH  
United Kingdom  
Tel+441243863121  
Fax+441243845354

### For Central and Eastern Europe, please contact:

#### Fisher-Rosemount GmbH & Co. Diaphragm Seal Support

Argelsrieder Feld 7  
D-82234 Wessling  
Germany  
Tel (+49) (0) 8153 27-0  
Fax (+49) (0) 8153 27-172

### For Asia-Pacific, please contact your local Fisher Rosemount Representative

**Rosemount Inc.**  
8200 Market Boulevard  
Chanhassen, MN 55317 USA  
Tel 1-800-999-9307  
Telex 4310012  
Fax (612) 949-7001

© 1997 Rosemount, Inc.



<http://www.rosemount.com>

*The Model 3051C Pressure Transmitter may be protected by one or more of the following U.S. Pat. No.: 4,370,890; 4,612,812; 4,791,352; 4,798,089; 4,818,994; 4,833,922; 4,866,435; 4,926,340; 4,988,990; 5,028,746. MEXICO PATENTADO NO. 154,961. May Depend on Model. Other U.S. and Foreign Patents Issued and Pending.*

*The Model 1151 Pressure Transmitter may be protected by one or more of the following U.S. Patent Nos. 3,854,039; 3,975,719; 4,339,750; and Re. 30, 603. Mexico Patentado No. 136,497. May depend on model. Other foreign patents issued and pending.*

*The Model 2088 Pressure Transmitter may be protected by the following U.S. Patent Nos.: 4,970,898 and 5,083,091. May depend on Model. Other U.S. and Foreign Patents Issued and Pending.*

*Rosemount, the Rosemount logotype, and Alphaline are registered trademarks of Rosemount Inc. HART is a registered trademark of the HART Communication Foundation. Tri-Clamp is a registered trademark of Tri-Clover Inc. of the Alfa-Laval Group. The 3-A symbol is a registered trademark of the 3-A Sanitary Standards Symbol Council. Grafoil is a trademark of Union Carbide Corp. Teflon is a registered trademark of E.I. du Pont de Nemours & Co.*

*Cover Photos: 1199-039AB, 034AB, 051AB, 041AB, 077AB, 074AB, 038AB, 042AB, 063AB.*



Fisher-Rosemount satisfies all obligations coming from legislation to harmonize product requirements in the European Union.



# ROSEMOUNT®

**FISHER-ROSEMOUNT™ Managing The Process Better.™**





---

# Table of Contents

<b>SECTION 1</b>	Introduction .....	1-1
<b>Introduction</b>		
<b>SECTION 2</b>	Seals Handling and Installation Considerations .....	2-1
<b>Installation</b>	Tagging .....	2-2
	Flanged Type Seals: Flush or Extended Diaphragm .....	2-2
	Pancake Type Seals .....	2-3
	Threaded Type Seals .....	2-4
	Saddle Type Seals .....	2-5
	In-line Flow-Through Seals .....	2-5
	Sanitary Tank Spud Seals .....	2-6
	Sanitary Flanged Tank Spud Seals .....	2-6
	Sanitary Tri-Clamp® Seals .....	2-7
	Sanitary Threaded Type Seals .....	2-7
<b>SECTION 3</b>	Application Considerations .....	3-1
<b>Calibration</b>	Zero Suppression .....	3-1
	Zero Elevation .....	3-1
	Maximum Span Calculation .....	3-1
	Electronics Considerations .....	3-2
	Maximum Span .....	3-2
	Calibrating a One Seal System with Suppressed Zero (Transmitter Mounted Below the High Side Tap) .....	3-3
	Calibrating a One-Seal System with Elevated Zero (Transmitter Mounted Above the High Side Tap) .....	3-4
	Calibrating a Two-Seal System with Elevated Zero (Transmitter Mounted Level with, Above, or Below the High Pressure Tap) .....	3-5
<b>SECTION 4</b>	Cleaning .....	4-1
<b>Maintenance and</b>	Troubleshooting .....	4-1
<b>Troubleshooting</b>	Return of Materials .....	4-2

---

# Introduction

## Introduction

A diaphragm seal system consists of a pressure transmitter, a diaphragm seal, a fill fluid, and either a direct mount or capillary style connection.

During operation, the thin, flexible diaphragm and fill fluid separate the pressure sensitive element of the transmitter from the process medium. The capillary tubing or direct mount flange connects the diaphragm to the transmitter.

When process pressure is applied, the diaphragm is displaced, transferring the measured pressure through the filled system, by way of the capillary tubing, to the transmitter element. This transferred pressure displaces the sensing diaphragm in the pressure-sensitive element of the transmitter. This displacement is proportional to the process pressure and is converted electronically to an appropriate current, voltage, or digital HART<sup>®</sup> (Highway Addressable Remote Transducer) output signal.

This manual is designed to assist in installing, operating, and maintaining the Rosemount Model 1199 Filled Systems for Pressure Transmitters. The manual contains supplemental information about the transmitter/seal system that is not covered in the correlative transmitter manual.

The information is organized into the following categories:

- Installation
- Calibration
- Maintenance/Troubleshooting

See Product Data Sheets 00813-0100-4016 in North America or 00813-0201-4016 in Europe for more detailed information on specific Rosemount diaphragm seals.



## Installation

This section contains installation information for various types of Model 1199 Diaphragm Seals including:

Seals Handling and Installation Considerations

Tagging

Flanged Type Seals

Pancake Type Seals

Threaded Type Seals

Saddle Seals

In-Line Flow-Through Seals

Sanitary Tank Spud Seals

Sanitary Tri-Clamp Seals.

Sanitary Threaded Type Seals

Additional specialized diaphragm seals are available. Contact Rosemount Diaphragm Seal Support for installation information on these seals.

### Seals Handling and installation Considerations

When unpacking or handling a transmitter/seal system, do not lift the seal or transmitter by gripping the capillaries.

Avoid sharply bending or crimping the capillary tubing. The minimum bending radius of the capillary tubing is three inches (8 centimeters).

---

#### NOTE

**NEVER** attempt to disconnect the seals or capillaries from the transmitter. Doing so will result in loss of fill fluid and will void the product warranty.

---

The material of a diaphragm seal is designed to withstand pressure and wear from process material, but outside of process connection conditions, diaphragm seals are relatively delicate and should be handled with care.

The protective cover should remain on the seal until the moment before installation. Try to avoid touching the diaphragm with fingers or objects and refrain from setting the diaphragm side of the seal down on a hard surface. Even minor dents or scratches in the diaphragm material may impair the performance of the transmitter/seal system.

When installing diaphragm seal systems which employ a gasket or a gasket and flushing connection ring, make sure the gasket is aligned properly on the gasket sealing surface.

Most importantly, make sure the gasket does not press down upon the diaphragm face. Anything pressing on the diaphragm will be read by the transmitter as pressure. A misaligned gasket may cause a false reading.

## Tagging

Each diaphragm seal system is tagged in accordance with the customer requirements. The standard tag is attached to the transmitter/seal system. Tag is 0.020 in. (0.051cm) thick with 0.125 in. (0.318 cm) high letters. A sample tag is shown below. 3-A<sup>®</sup> approved sanitary seal systems have a 3-A symbol marked on the diaphragm seal.

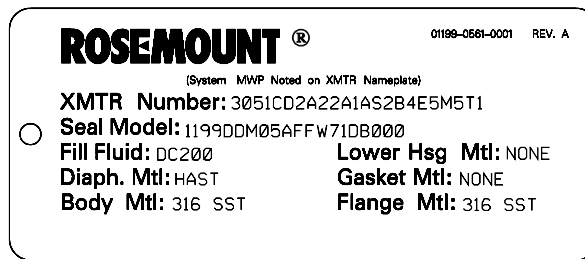

1199-0561A01A

The Maximum Working Pressure (MWP) of the transmitter/seal system is stamped on the transmitter neck tag. This is dependent upon the maximum pressure rating of the seal system or transmitter upper range limit.

## Flanged Type Seals: Flush or Extended Diaphragm

FIGURE 2-1. Flanged Type Seal.

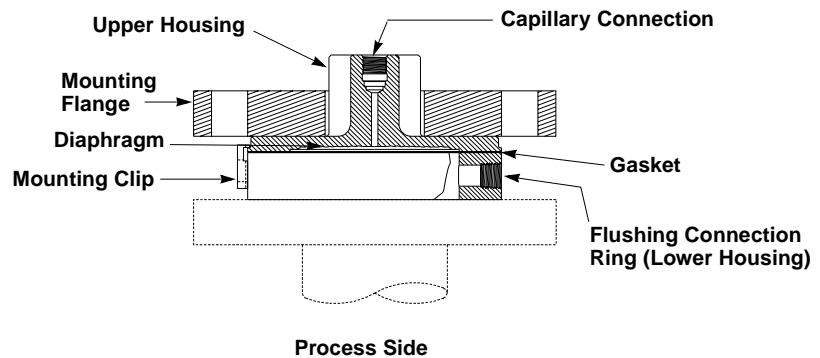

3051A23C

### Bolt Torquing

When connecting the process and mating flange, the bolts should be torqued to the applicable flange requirements. Required torque is a function of the gasket material and surface treatment of the bolts and nuts which are customer supplied.

### Flushing Connection Ring Installation

The flanged type seals are available with an optional flushing connection ring (or lower housing.) For certain seal types the flushing connection ring is supplied with four clips and screws that hold the diaphragm seal to the lower housing in order to make installation easier.

### Gasket Installation

When connecting the diaphragm seal, gasket, and flushing connection ring make sure the gasket is properly aligned on the gasket sealing surface.

## Pancake Type Seals

FIGURE 2-2. Pancake Type Seal.

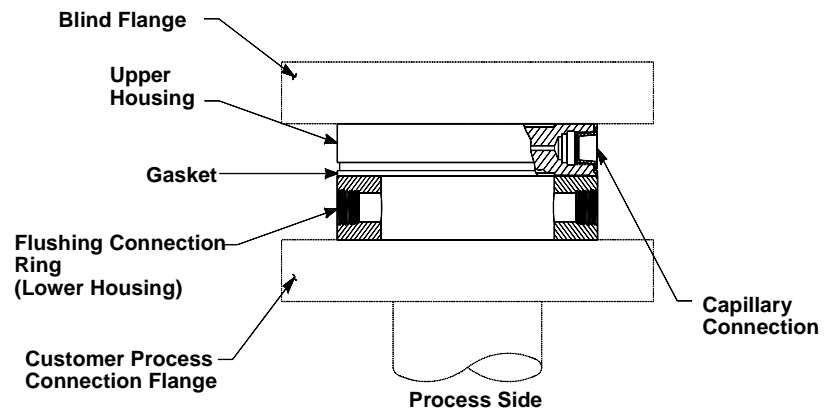

3051-3031E23B

### Capillary Support Tube

A common option for the Pancake type seal is the capillary support tube. Due to the side capillary-to-seal connection, the support tube provides a handle for aligning the Pancake seal during installation. The support tube should not be used for supporting any weight.

### Blind Flange

Rosemount offers the option of supplying the blind flange, otherwise the blind flange is furnished by the customer. For certain pancake seal assemblies, the Rosemount supplied blind flange has a machined hole through the center of the flange. This hole corresponds to a threaded connection in the back of the pancake seal upper housing. The flange can, therefore be connected to the seal prior to installation to make handling easier.

### Bolt Torquing

When connecting the process and mating flange, the bolts should be torqued to the applicable flange requirements. Required torque is a function of the gasket material and surface treatment of the bolts and nuts which are customer supplied.

### Flushing Connection Ring Installation

The Pancake type seals are available with an optional flushing connection ring (or lower housing). For certain seal types the flushing connection ring is supplied with four clips and screws that attach the diaphragm seal to the lower housing in order to make installation easier.

### Gasket Installation

When connecting the diaphragm seal, gasket, and flushing connection ring make sure the gasket is properly aligned on the gasket sealing surface.

## Threaded Type Seals

FIGURE 2-3. Female Threaded Type Seal.

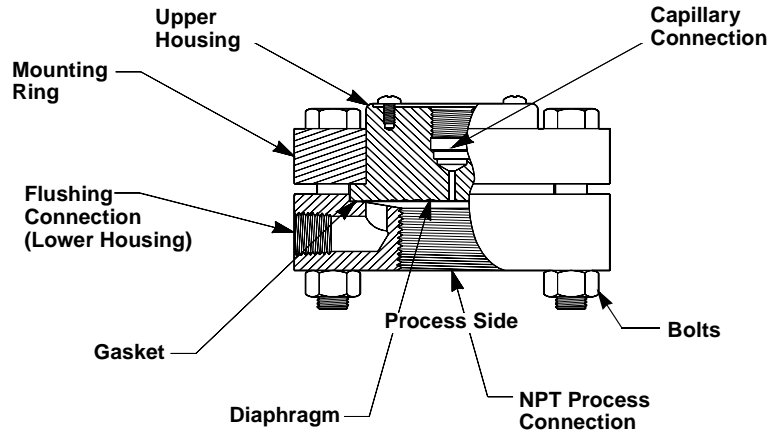

3051-3031D23B

### Lower Housing Installation Procedure

The threaded seal is preassembled at the factory; meaning the upper housing and lower housings are bolted together at the required torque specifications. The lower housing of the diaphragm seal has either a male or female thread connection for attachment to a process pipe nipple. When threading the lower housing to the process pipe, care should be taken not to overtighten. The applied torque should comply to ANSI B1.20.1 or applicable torque requirements for pipe connections.

### Upper Housing Installation

The threaded seal is supplied with carbon steel, 304 SST, or 316 SST bolts and nuts. The torque specifications for the bolts attaching the upper and lower seal housing are specified on the seal torque label for certain seal types. The torque specifications for the RTW seal is a minimum of 135 in-lbs (15 N-m), for all bolt materials.

### Gasket Installation

Threaded seals with flushing connection rings come with a sealing gasket. When connecting the diaphragm seal, gasket, and flushing connection ring make sure the gasket is properly aligned on the gasket sealing surface.

### Alternative System Installation Procedure

An alternative to threading the entire transmitter/seal system to the process piping is to unbolt the seal upper and lower housing and thread the lower housing to the hard piping separately. Bolt the upper and lower housings together to the required torque specification.

Note that certain gaskets, such as Grafoil™ or Teflon® (PTFE), need to be replaced once they have been torqued. Thus this alternative system installation procedure may require gasket replacement.

## Saddle Type Seals

FIGURE 2-4. Saddle Type Seal.

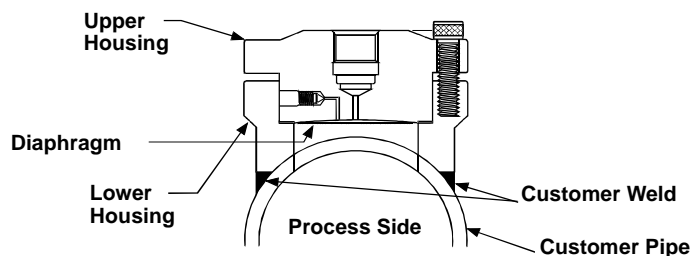

1199-9004A03A

### Lower Housing Installation

The lower housing is welded directly into the process pipe. The upper housing must be removed from the system when welding the lower housing into the process pipe. Allow the pipe connection to cool before installing the seal upper housing.

### Upper Housing Installation

The torque specifications for the saddle seal upper housings are 360 in-lbs (40 N-m) with carbon steel bolts or 180 in-lbs (20 N-m) with stainless steel bolts. As it is necessary for the customer to torque the upper housing bolts during installation, each saddle seal includes a torque label with the specified torque.

### Gasket Installation

The saddle comes standard with a sealing gasket. When connecting the upper and lower housings make sure the gasket is aligned properly on the gasket sealing surface.

## In-line Flow-Through Seals

FIGURE 2-5. In-line Flow Through Seal with Threaded Connection.

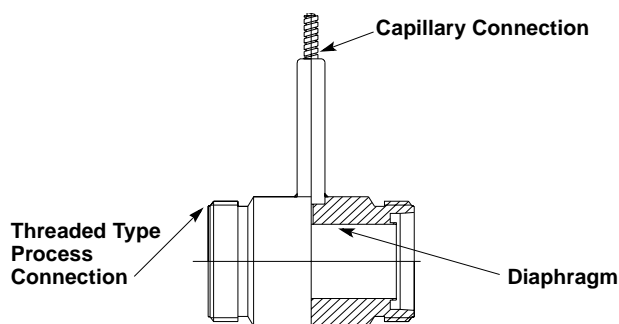

1199-0000C12B

### Handling

Care should be taken to ensure the seal diaphragm is not dented or damaged during seal installation. The diaphragm seal protective covers should remain on the seal until just prior to installation.

### Connection Styles

The in-line flow-through seal is attached to the process piping by either flange, clamp or male threaded connections.

#### Flanged Type Connection

The flanged process connection sandwiches the flow-through seal between two process flanges, either direct welded to the seal or supplied loosely. The bolts should be torqued to the specifications outlined by ANSI B16.5 or applicable flange torque requirements. Required torque is a function of the gasket material and surface treatment of the bolts and nuts, which are customer supplied.

#### Clamp Type Connection

The clamp connection provides a sanitary fitting that attaches the flow-through seal to the process piping by two sanitary Tri-Clamp clamps.

#### Threaded Type Connection

The male threaded process connection allows the in-line seal to be threaded into the female process piping according to DIN 11851, SMS, IDF, or RJT standards.

## Sanitary Tank Spud Seals

FIGURE 2-6. Sanitary Tank Spud and Sanitary Tank Spud Seal.

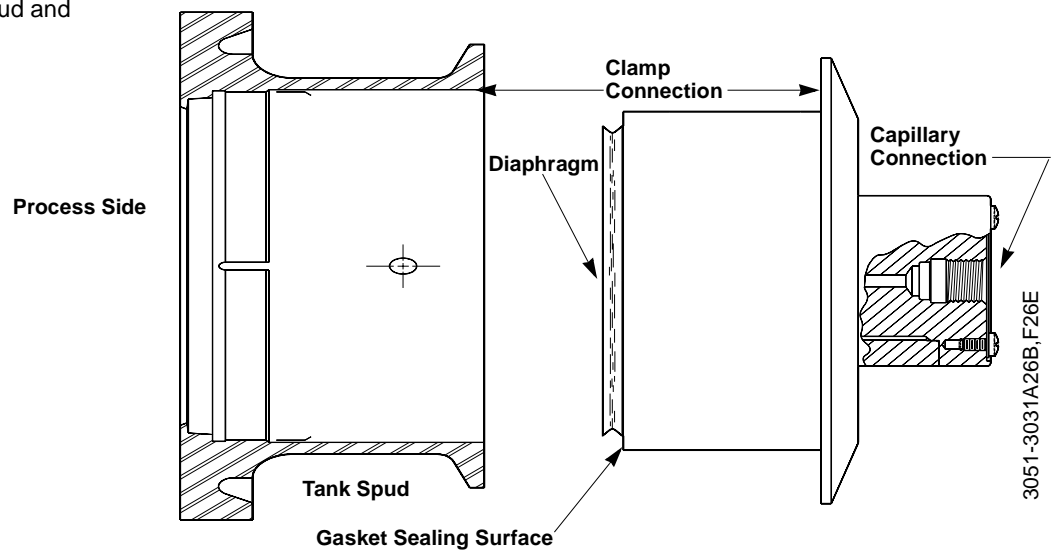

## Sanitary Flanged Tank Spud Seals

FIGURE 2-7. Sanitary Flanged Type Tank Spud Seal.

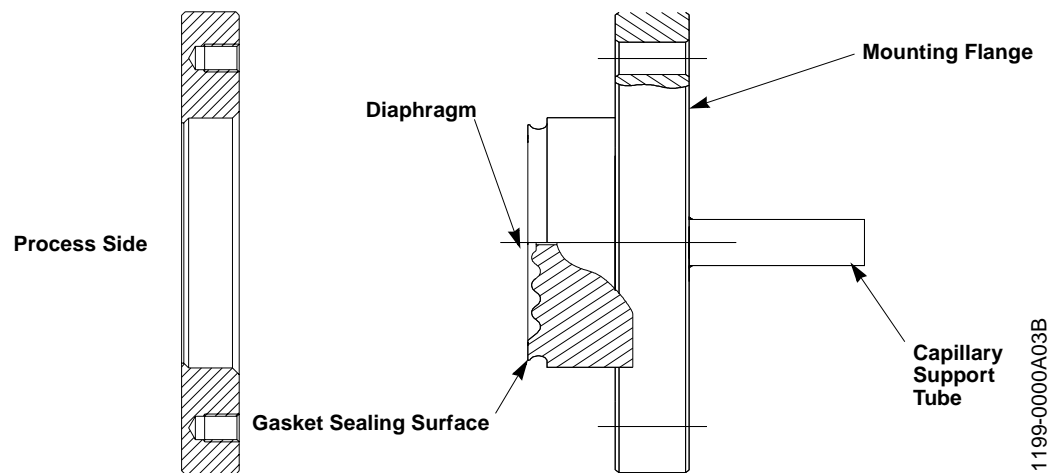

### Sanitary Approvals

Rosemount supplied 3-A approved sanitary seals have a 3-A symbol marked on the diaphragm seal.

### Clamp Style Tank Spud

For clamp style tank spud seals the procedures for welding the tank spud to the tank vessel are shipped with the tank spud. For the welding procedure refer to Manual Supplement MAN 4016-1.

The clamp and O-ring is provided with the tank spud seal. Attach the clamp and hand-tighten the connection.

### Flange Style Tank Spud

When connecting the process and mating flange, the bolts should be torqued to the specifications outlined by ANSI B16.5 or applicable flange requirements.

## Sanitary Tri-Clamp® Seals

FIGURE 2-8. Sanitary Tri-Clamp Diaphragm Seal.

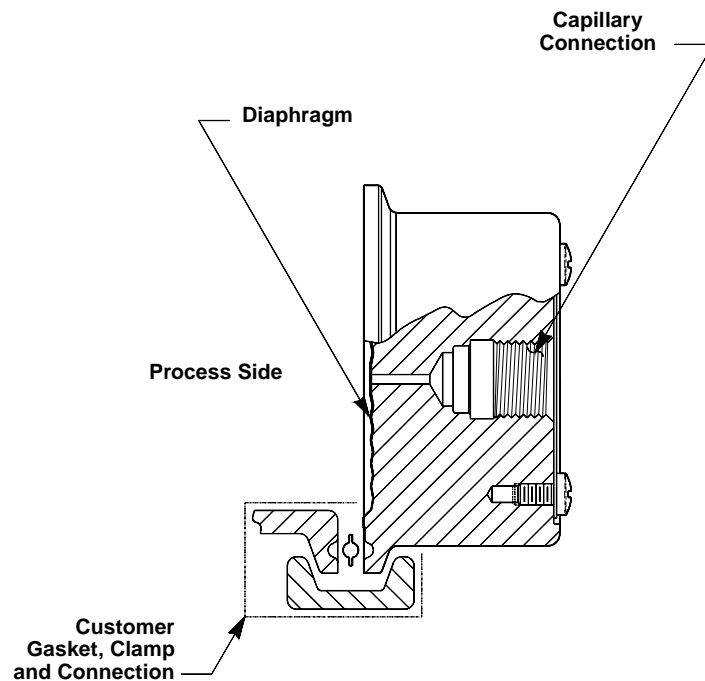

3051-3031F26B

### Sanitary Approvals

Rosemount supplied 3-A approved sanitary seals have a 3-A symbol marked on the diaphragm seal.

### Clamp and Gasket

The clamp and gasket are furnished by user, unless specified by customer. Maximum pressure rating of the system is dependent upon the clamp device, for high pressure clamps up to 1,000 psi (69 bar) contact the factory. To install, attach and hand tighten the clamp.

## Sanitary Threaded Type Seals

FIGURE 2-9. Sanitary Threaded Type Seals, Dairy Process Connections.

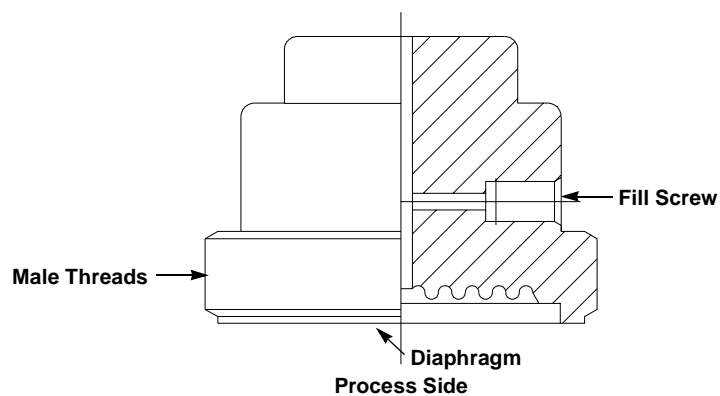

1199-

### Installation

Threaded sanitary seals need to be installed following the installation instructions for the respective DIN 11851, SMS, RJT, or IDF couplings.



**APPLICATION  
CONSIDERATIONS**

Diaphragm seal installations frequently require transmitters to be calibrated with *suppressed or elevated zeroes*. For more extensive calibration information see the applicable transmitter manual.

**Zero suppression**

A suppressed zero is needed when a gage or absolute pressure transmitter is mounted below the high side tap (the bottom process connection). When the transmitter is mounted below the high side tap, the fill fluid in the capillary puts pressure on the transmitter sensor causing it to give a positive pressure reading even when the tank is empty.

**Zero elevation**

Conversely, an elevated zero is needed for a gage or absolute transmitter mounted above the high side tap (the bottom process connection) or for a two seal differential pressure application. In these cases, the transmitter reads a negative pressure when the tank is empty, due to the head pressure effect of the capillary fill fluid.

**Maximum Span  
Calculation**

Example 1 calculates the maximum amount of zero elevation or suppression for a transmitter of a specific range. The results of the calculation will help in determining the mounting location for the transmitter.

**Example 1**

Mounting Considerations for a Model 3051 Range 2 Transmitter/Seal System.

Maximum height of process fluid (H) = 65 inches (165 cm)

Specific gravity of the process fluid ( $s_p$ ) = 1.0 inH<sub>2</sub>O/inch,  
( $\rho_p$ ) = (1 000 kg/cm<sup>3</sup>)

Transmitter Lower Range Limit (LRL) = -250 inH<sub>2</sub>O (- 620 mbar)

Transmitter Upper Range Limit (URL) = 250 inH<sub>2</sub>O (620mbar)

Specific gravity of the (Inert) capillary fill fluid ( $s_f$ ) = 1.85 inH<sub>2</sub>O/inch  
 $\rho_f$  = (1 850 kg/m<sup>3</sup>)

Gravity Constant (g) for SI Units: 9,81 m/s<sup>2</sup>

**American Units**

**Step 1**    **URL > (h) ( $s_f$ ) + (H) ( $s_p$ ) > LRL**

**Step 2**    **250 inH<sub>2</sub>O > (h) (1.85 inH<sub>2</sub>O/inch) + (65 inches) (1.0 inH<sub>2</sub>O/inch) > -250**

**Step 3**    **185 inH<sub>2</sub>O > (h) (1.85 inH<sub>2</sub>O/inch) > -315 inH<sub>2</sub>O**

**Step 4**    **100 inches > (h) > -170 inches**

SI Units	<p><b>Step 1</b>    <math>URL &gt; \rho_f \cdot g \cdot h + \rho_p \cdot g \cdot H &gt; LRL</math></p> <p><b>Step 2</b>    <math>620(\text{mbar}) &gt; h \cdot 9,81 \cdot \frac{1850(\frac{\text{mbar}}{\text{m}})}{100} + (1,5\text{m}) \cdot 9,81 \cdot \frac{1000(\frac{\text{mbar}}{\text{m}})}{100} &gt; -620(\text{mbar})</math></p> <p style="margin-left: 2em;"><math>620(\text{mbar}) &gt; h \cdot 9,81 \cdot 18,5(\frac{\text{mbar}}{\text{m}}) + (1,5\text{m}) \cdot 9,81 \cdot 10(\frac{\text{mbar}}{\text{m}}) &gt; -620(\text{mbar})</math></p> <p><b>Step 3</b>    <math>\frac{(620 - 147)(\text{mbar})}{182(\frac{\text{mbar}}{\text{m}})} &gt; h &gt; \frac{(-620 - 147)(\text{mbar})}{182(\frac{\text{mbar}}{\text{m}})}</math></p> <p><b>Step 4</b>    = 2,6 meters &gt; h &gt; 4,2 meters</p>
----------	---

---

**NOTE**

$$\frac{1 \text{ mbar}}{100} = (1 \text{ kg/m}^3) \cdot (1 \text{ m/s}^2) \cdot (1 \text{ m}) = 1 \text{ N/m}^2$$

---

where:

(h) is the distance between the transmitter and the high pressure tap. (h) is positive if the transmitter is mounted below the high pressure tap and is negative if it is mounted above the tap. In this case for a:

**One Seal System Suppressed Zero (transmitter mounted below the high pressure tap)**

Do not mount the transmitter below the seal more than 100 inches (2,6 meters) below the seal.

**One Seal System Elevated Zero (transmitter mounted above the high pressure tap)**

Do not mount the transmitter more than 170 inches (4,2 meters) above the seal.

**Two Seal System Elevated Zero (independent of transmitter location)**

If it is necessary to measure an empty tank condition, the distance between the seal taps should not exceed 170 inches (4,2 meters).

**Electronics Considerations**

Zero elevation and suppression must be such that the lower range value does not exceed the transmitter lower range limit (LRL), and the upper range value is less than or equal to the transmitter upper range limit (URL). The calibrated span must be greater than or equal to the minimum span.

**Maximum Span**

For applications in which the transmitter is mounted above or below the high pressure tap, be sure the calibrated span does not exceed the transmitter minimum and maximum span limits.

---

**NOTE**

For the Model 3051 and 1151 Smart Transmitters, the maximum span equals the difference between the upper and lower range limits. For example, a Model 3051CD2 (Range Code 2) transmitter that has an upper range limit of 250 inH<sub>2</sub>O (620 mbar) and a lower range limit of -250 inH<sub>2</sub>O (- 620 mbar) has a maximum span capability of 500 inH<sub>2</sub>O (1,24 bar).

---

### Calibrating a One Seal System With Suppressed Zero (Transmitter Mounted Below the High Side Tap)

Given:  
 DC 200 fill fluid  
 $(s_f) = 0.93 \text{ in H}_2\text{O/inch}$   
 $(h) = 40 \text{ inches}$   
 $(s_p) = 1.2 \text{ in H}_2\text{O/inch}$   
 $(H) = 120 \text{ inches}$

Given:  
 Fill fluid  
 $(\rho_f) = 930 \text{ kg/m}^3$   
 $(h) = 1 \text{ meter}$   
 $(\rho_p) = 1200 \text{ kg/m}^3$   
 $(H) = 3 \text{ meters}$   
 $(g) = 9.81 \text{ m/s}^2$

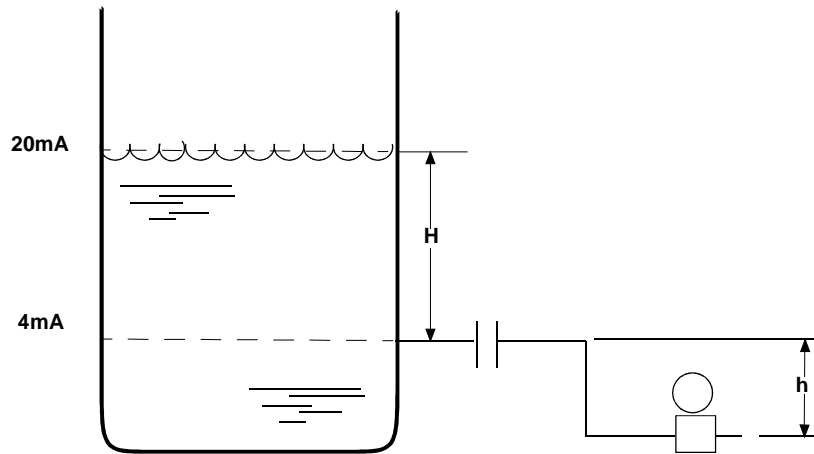

FIGURE 3-1. Transmitter Mounted Below the High Side Tap.

1. Calculate the amount of zero suppression by multiplying the distance between the process connection and the transmitter ( $h$ ) by the fill fluid specific gravity ( $s_f$ ).

**American Units**

**Step 1 Zero Suppression =  $(h)(s_f)$**   
 $= (40 \text{ inches})(0.93 \text{ inH}_2\text{O/inch}) = 37.2 \text{ inH}_2\text{O}$

2. Calculate the span by multiplying the maximum process fluid height ( $H$ ) by the specific gravity of the process liquid ( $s_p$ ).

**Step 2 Span =  $(H)(s_p)$**   
 $= (120 \text{ inches})(1.2 \text{ inH}_2\text{O/inch}) = 144 \text{ inH}_2\text{O}$

3. Calibrate the transmitter using the following equation:

**Step 3 Calibration = Zero Suppression to (Zero Suppression + Span)**  
 $= 37.2 \text{ to } (37.2 + 144 \text{ inH}_2\text{O})$   
**Step 4 = 37.2 to 181.2 inH<sub>2</sub>O**

**SI Units**

**Step 1 Zero Suppression =  $\rho_f \cdot g \cdot h = 930 \cdot 9.81 \cdot \frac{1}{100} \text{ mbar} = 91.2 \text{ mbar}$**

**Step 2 Span =  $H \cdot \rho_p \cdot g = \frac{3}{100} \cdot 1200 \cdot 9.81 \text{ mbar} = 353 \text{ mbar}$**

**Step 3 Calibration**  
 $4\text{mA} = \text{Zero Suppression} = 91.2 \text{ mbar}$   
 $20\text{mA} = \text{Zero Suppression} + \text{Span}$   
 $= 91.2 \text{ mbar} + 353 \text{ mbar}$   
 $= 444.2 \text{ mbar}$

**Summary**

Therefore, in this example, a Model 3051C Range 2, URL = 250 inH<sub>2</sub>O (620 mbar), Model 1151Range 5, URL = 750 inH<sub>2</sub>O (1,9 mbar), or Model 2088 Range 0, URL = 220 inH<sub>2</sub>O (550 mbar) transmitter is required.

**NOTE**

$\frac{1 \text{ mbar}}{100} = (1 \text{ kg/m}^3) \cdot (1 \text{ m/s}^2) \cdot (1 \text{ m}) = 1 \text{ N/m}^2$

1199-0160J

### Calibrating a One-Seal System With Elevated Zero (Transmitter Mounted Above the High Side Tap)

Given:  
 Inert fill fluid  
 $(s_f) = 1.9 \text{ in H}_2\text{O/inch}$   
 $(-h) = -30 \text{ inches}$   
 $(s_p) = 1.1 \text{ in H}_2\text{O/inch}$   
 $(H) = 120 \text{ inches}$

Given:  
 Inert fill fluid  
 $(\rho_f) = 1850 \text{ kg/m}^3$   
 $(-h) = 0,75 \text{ m}$   
 $(\rho_p) = 1100 \text{ kg/m}^3$   
 $(H) = 3 \text{ m}$   
 $(g) = 9,81 \text{ m/s}^2$

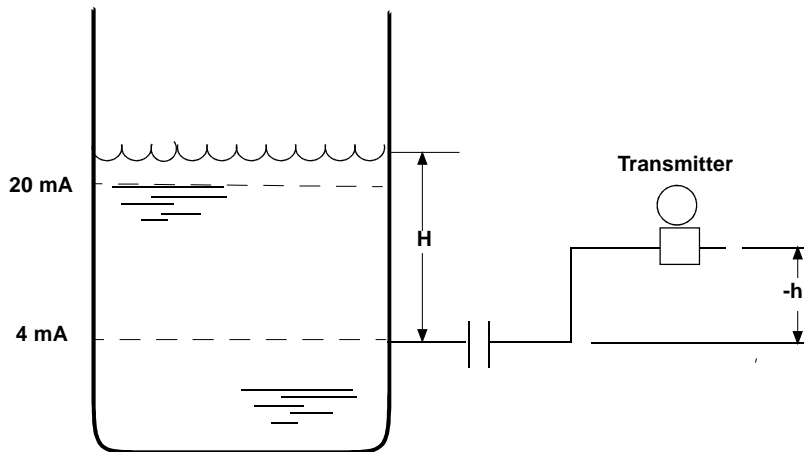

FIGURE 3-2. Transmitter Mounted Above a Single Seal.

1199-0160k

#### American Units

1. Calculate the amount of zero elevation by multiplying the height of the transmitter above the process connection (-h) by the specific gravity of the fill fluid ( $s_f$ ).  
**Step 2 Zero Elevation = (-h)( $s_f$ )**  
**= (-30 inches) (1.9 inH<sub>2</sub>O/inch) = -57 inH<sub>2</sub>O**
2. Calculate the transmitter span by multiplying the maximum height of the process fluid (H) by the specific gravity of the process liquid ( $s_p$ ).  
**Step 2 Span = (H)( $s_p$ )**  
**= (120 inches) (1.1 inH<sub>2</sub>O/inch) = 132 inH<sub>2</sub>O**
3. Calibrate the transmitter using the following equation:  
**Step 3 Calibration = Zero Elevation to (Zero Elevation + Span)**  
**= -57 inH<sub>2</sub>O to (-57 + 132 inH<sub>2</sub>O)**  
**Step 4 = -57 inH<sub>2</sub>O to 75 inH<sub>2</sub>O**

#### SI Units

- Step 1 Zero Elevation =  $-\rho_f \cdot g \cdot h$**   
 $= -1850 \cdot 9,81 \cdot \frac{0,75}{100} \text{ mbar}$   
 $= -136 \text{ mbar}$
- Step 2 Span =  $\rho_p \cdot g \cdot H$**   
 $= 1100 \cdot 9,81 \cdot \frac{3}{100} \text{ mbar}$   
 $= 324 \text{ mbar}$
- Step 3 Calibration:**  
 $4\text{mA} = \text{Zero Elevation} = -136 \text{ mbar}$   
 $20\text{mA} = \text{Zero Elevation} + \text{Span} = -136 + 324 \text{ mbar}$   
 $= 188 \text{ mbar}$

#### Summary

Therefore, in this example, a Model 3051CG Range 2, URL = 250 inH<sub>2</sub>O (620 mbar), Model 1151 Range 4, URL = 150 inH<sub>2</sub>O (375 mbar), or Model 2088 Range 0, URL = 220 inH<sub>2</sub>O (550 mbar) transmitter is required.

#### NOTE

$$\frac{1 \text{ mbar}}{100} = (1 \text{ kg/m}^3) \cdot (1 \text{ m/s}^2) \cdot (1 \text{ m}) = 1 \text{ N/m}^2$$

### Calibrating a Two-Seal System With Elevated Zero (Transmitter Mounted Level With, Above, or Below the High Pressure Tap)

Given:  
 DC 704 fill fluid  
 $(S_f) = 1.07 \text{ in H}_2\text{O/inch}$   
 $(-h) = -400 \text{ inches}$   
 $(S_p) = 0.9 \text{ in H}_2\text{O/inch}$   
 $(H) = 350 \text{ inches}$

Given:  
 High Temperature  
 Silicone Oil fill fluid  
 $(\rho_f) = 1\,070 \text{ kg/m}^3$   
 $(-h) = -10 \text{ meters}$   
 $(\rho_p) = 900 \text{ kg/m}^3$   
 $(H) = 8,5 \text{ meters}$   
 $(g) = 9,81 \text{ m/s}^2$

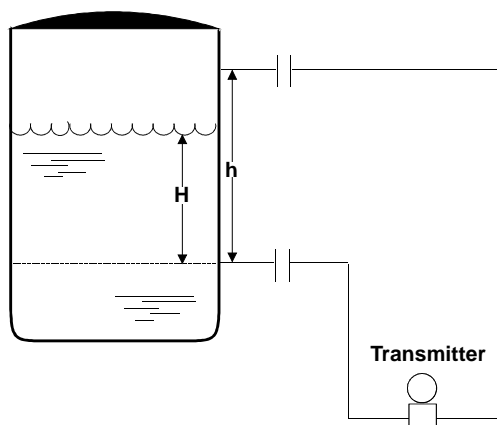

FIGURE 3-3. Transmitter with Two-Seal System.

1199-0160L

#### American Units

1. Calculate the amount of zero elevation by multiplying the distance between the process connections (h) by the specific gravity of the fill fluid ( $s_f$ ).

**Step 1 Zero Elevation =  $-(h)(s_f)$**   
 $= - (400 \text{ inches}) (1.07 \text{ inH}_2\text{O/inch}) = - 428 \text{ inH}_2\text{O}$

2. Calculate the span by multiplying the maximum height of the process fluid (H) by the specific gravity of the process liquid ( $s_p$ ).

**Step 2 Span =  $(H)(s_p)$**   
 $= (350 \text{ inches}) (0.9 \text{ inH}_2\text{O/inch}) = 315 \text{ inH}_2\text{O}$

3. Calibrate the transmitter using the following equation:

**Step 3 Calibration = Zero Elevation to (Zero Elevation + Span)**  
 $= - 428 \text{ inH}_2\text{O to } (- 428 + 315 \text{ inH}_2\text{O})$

**Step 4 = - 428 inH<sub>2</sub>O to - 113 inH<sub>2</sub>O.**

#### SI Units

**Step 1 Zero Elevation =  $-\rho_f \cdot g \cdot h$**   
 $= -1070 \cdot 9,81 \cdot \frac{10}{100} \text{ mbar}$   
 $= -1050 \text{ mbar}$

**Step 2 Span =  $\rho_p \cdot g \cdot H$**   
 $= 900 \cdot 9,81 \cdot \frac{8,5}{100} \text{ mbar}$   
 $= 750 \text{ mbar}$

**Step 3 Calibration:**

$4\text{mA} = \text{Zero Elevation} = -1050 \text{ mbar}$   
 $20\text{mA} = \text{Zero Elevation} + \text{Span} = -1050 + 750 \text{ mbar}$   
 $= -300 \text{ mbar}$

#### Summary

In this example a Model 3051CD Range 3, URL = 1,000 inH<sub>2</sub>O (2,5 bar) or a Model 1151DP Range 5, URL = 750 inH<sub>2</sub>O (1,9 bar) transmitter is required.

**NOTE**

$\frac{1 \text{ mbar}}{100} = (1 \text{ kg/m}^3) \cdot (1 \text{ m/s}^2) \cdot (1 \text{ m}) = 1 \text{ N/m}^2$

FIGURE 3-4. Recommended Mounting Configuration for Vacuum Applications.

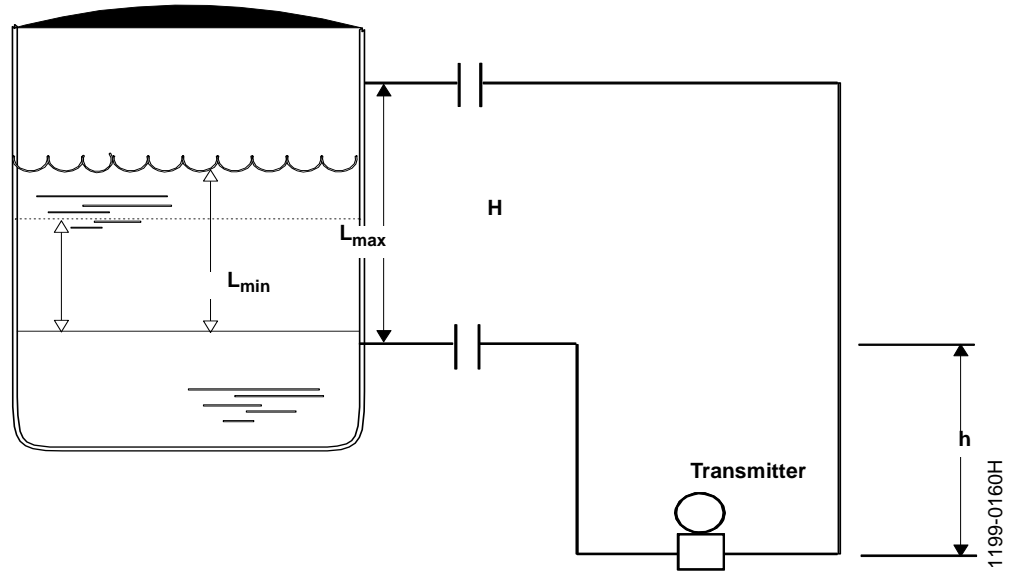

When installing diaphragm seals in vacuum applications:

1. Consult vapor pressure curves to determine that the correct fill fluid has been selected. Always compare against the minimum vacuum pressure and the maximum process temperature.
2. Always mount the transmitter below the bottom tap.
3. If in doubt, consult your local Rosemount Measurement Division representative or contact the nearest Rosemount Diaphragm Seal Support Center for guidance.

# Maintenance and Troubleshooting

## Cleaning

Avoid using abrasive agents or high pressure water jets when cleaning the diaphragm seals.

## Troubleshooting

Diaphragm seal systems are factory filled systems that cannot be refilled in the field. **Do not** attempt to disconnect the seals or capillaries from the transmitter. Doing so can damage the transmitter/seal system and voids the product warranty. The table below lists possible problems, their potential sources, and, where applicable, a corrective action.

TABLE 4-1. Troubleshooting Seal Systems.

PROBLEM NO RESPONSE		
Symptom	Potential Source	Corrective Action
No output	Electrical problem Electronic problem	See the troubleshooting section of the transmitter manual for more extensive information. Check for adequate voltage to the transmitter. Check the milliampere rating of the power supply against the total current being drawn for all transmitters being powered. Check for shorts and multiple grounds. Check for proper polarity at the transmitter terminal. Check loop impedances.  <div style="border: 1px solid black; padding: 5px; text-align: center;"> <p><b>⚠ CAUTION</b></p> <p>Do not use higher than the specified voltage to check the loop, or the transmitter electronics may be damaged.</p> </div> See if the transmitter is in a multidrop mode. The multidrop mode locks the output at 4mA.
Output saturated high	Elevation/suppression jumper  Air in system on high side Loss of fill fluid on low side	See the “Zero Adjustment Range” information in the Calibration section of the transmitter manual for jumper setting instructions. Diaphragm systems are factory sealed. Consult the factory. Diaphragm systems are factory sealed. Consult the factory.
Output saturated low	Elevation/suppression jumper  Air in system on low side Loss of fill fluid on high side	See the “Zero Adjustment Range” information in the Calibration section of the transmitter manual for jumper setting instructions. Diaphragm systems are factory sealed. Consult the factory. Diaphragm systems are factory sealed. Consult the factory.
Output will not change with pressure	Complete loss of fill fluid	Diaphragm systems are factory sealed. Consult the factory.
SLOW RESPONSE		
Symptom	Potential Source	Corrective Action
Slow response	Damping too high  Cold Temperature  Fill fluid low	See the “Damping Adjustment” information in the Calibration section of the transmitter manual. Fill fluid viscosity is temperature dependent, less viscous fill fluid enhances time response. Diaphragm systems are factory sealed. Consult the factory.
DRIFTING		
Symptom	Potential Source	Corrective Action
Drifting	Temperature effect Air in system	Diaphragm systems are factory sealed. Consult the factory. Diaphragm systems are factory sealed. Consult the factory.

## Return of Materials

Within the United States, call the Rosemount North American Response

TABLE 4-1. (continued). Troubleshooting Seal Systems.

<b>WILL NOT ZERO Symptom</b>	<b>Potential Source</b>	<b>Corrective Action</b>
Will not zero	Transmitter position O-Ring position Air under diaphragm Elevation/suppression jumper	Check for over-ranging transmitter. Make sure O-ring is not in contact with sensing diaphragm. Check for over-ranging transmitter. See the "Zero Adjustment Range" information in the Calibration section of the (analog transmitters only).

Center using the 1-800-654-RSMT (7768) toll-free number. This center, available 24 hours a day, will assist you with any needed information or materials.

Outside of the United States, contact the nearest Rosemount Diaphragm Seal Support Center, or contact your local Rosemount representative (Support Center addresses and phone numbers are on the title page of this manual).

The center will ask for product model and serial numbers, and will provide a Return Material Authorization (RMA) number. The center will also ask for the name of the process material the product was last exposed to.

**⚠ WARNING**

Mishandling products exposed to a hazardous substance can cause death or serious injury. If the product being returned was exposed to a hazardous substance as defined by OSHA, a copy of the required Material Safety Data Sheet (MSDS) for each hazardous substance identified must be included with the returned goods.



**For Western Europe, please contact:**

**Fisher- Rosemount  
Diaphragm Seal Support**

Heath Place  
Bognor Regis  
West Sussex PO229SH  
United Kingdom  
Tel+441243863121  
Fax+441243845354

**For Central and Eastern Europe, please  
contact:**

**Fisher-Rosemount GmbH & Co.  
Diaphragm Seal Support**

Argelsrieder Feld 7  
D-82234 Wessling  
Germany  
Tel (+49) (0) 8153 27-0  
Fax (+49) (0) 8153 27-172

**For Asia-Pacific, please contact your local  
Fisher Rosemount Representative**

**Rosemount Inc.**

8200 Market Boulevard  
Chanhassen, MN 55317 USA  
Tel 1-800-999-9307  
Telex 4310012  
Fax (612) 949-7001  
© 1997 Rosemount, Inc.



<http://www.rosemount.com>



00809-0100-4002 Rev. AD

**ROSEMOUNT®**

**FISHER-ROSEMOUNT™ Managing The Process Better.™**